



Commissioning Guide and
Maintenance Instructions

for Internally Ventilated DC Motor
GN..N with Ball Bearings

TAM 00520 / engl.
Date: 11/2007

	Technical Instructions Commissioning and Maintenance Guide	TAM 00 520 Page 1 / 18
---	---	----------------------------------

Commissioning Guide and Maintenance Instructions for Internally Ventilated DC Motors GN ..N with Ball Bearings



TABLE OF CONTENTS

1 Safety and Commissioning Information for Low-Voltage Machines (in accordance with Low-Voltage Guideline 73/23/EWG)	2
1.1 General.....	2
1.2 Appropriate Use.....	2
1.3 Transportation, Storage.....	3
1.4 Long-term storage.....	3
1.5 Setup.....	4
1.6 Electrical Connection.....	5
1.7 Operation.....	6
1.8 Electromagnetic Compatibility.....	6
1.9 Warranty.....	6
2 Information about the Product	7
2.1 Motor Type, Product Number and Technical Data.....	7
2.2 Types of Ventilation.....	7
2.3 Cooling.....	7
2.4 Necessary Cooling Air Volume and Pressure for fGN Motors.....	8
2.5 Fan Assignment for Series Motors.....	8
2.6 Noise Intensity for Series Motors.....	9
3 Operation	10
3.1 Instructions for Initial Commissioning.....	10
3.2 Wiring Diagrams.....	10
3.3 Notes.....	10
3.4 Allowed Radial Forces (with Standard Motor).....	11
3.5 Operating Disturbances.....	12
4 Corrective Maintenance	13
4.1 Brush-Holders, Carbon Brushes and Commutator of the Main Motor.....	13
4.2 Bearings.....	15
4.3 Intake opening for cooling air.....	15
4.4 Filters.....	16
5 List of Spare Parts and Sectional Drawing	16
6 Decommissioning, Removal, and Disposal	17

Always keep these operating instructions at hand at the machine's place of operation in the tool drawer or an appropriate container. The publication of this technical description invalidates all earlier information in previous documentation.

	Technical Instructions Commissioning and Maintenance Guide	TAM 00 520 Page 2 / 18
---	---	----------------------------------

Explanation of the symbols used for safety information:

	– This symbol shows information about protecting the system
	– This symbol shows general safety information for the protection of operating personnel
	– This symbol shows safety information about sources of electrical danger

1 Safety and Commissioning Information for Low-Voltage Machines (in accordance with Low-Voltage Guideline 73/23/EWG)



1.1 General

Even at a standstill, d.c. motors may, under some circumstances, have dangerous, **live, rotating** components that may have **hot** surfaces. All transportation and connection work as well as activities related to the commissioning and corrective maintenance of the equipment must be carried out by qualified, responsible specialists (observe **VDE 0105; IEC 364**). Inappropriate behaviour may result in serious **personal injury or damage to property**. The manufacturer accepts no responsibility for any and all damage resulting from inappropriate behaviour or behaviour that does not comply with applicable guidelines, specifications and legislation. Always observe **national, local and plant-specific regulations and requirements**.

Pay attention at all times to the warning signs and information plates mounted on the machine.

1.2 Appropriate Use

These motors are intended for **commercial** systems. They meet the harmonized standards of series **VDE 0530/EN 60034**.

	Technical Instructions Commissioning and Maintenance Guide	TAM 00 520 Page 3 / 18
---	---	----------------------------------

Use of this equipment in **hazardous locations is prohibited** unless expressly provided for (refer to additional information). **Never** use equipment with system of protection IP 23 or below out of doors. If special circumstances apply, e.g. the equipment is used in a **non-commercial** situation where stricter requirements must be met (such as special guards to protect children from moving parts, for example), these requirements must be met by the customer at setup. Motors **are rated for ambient temperatures of between + 5° C and + 40° C** and site altitudes of **1,000 metres above sea level or less**.

The permissible reference relative humidity levels in these cases are as follows: in the case of **indoor setup**, between **20% and 75%** in the temperature range **+5° C to +40° C**; with **outdoor setup**, between **36% and 98%** in the temperature range **+5° C to +40° C**. In this connection, with outdoor setup, the **absolute humidity** at more than **25° C must not rise above 23g/m³** (this corresponds to a relative humidity of 95% at 27° C).

Observe any information that differs from the data on the rating plate. On-site conditions at the place of use must correspond exactly with **all** the information on the rating plate.

Low-voltage machines are **components** for installation in machines in the sense of machine guideline **98/37/EG. Commissioning** may not be carried out until it has been determined that the end product conforms to this guideline (**observe EN 60204-I**).

1.3 Transportation, Storage

Immediately report any **damage** that you may have found after delivery to the carrier. If necessary, **commissioning should be postponed**. Tighten screwed-in transportation rings. These are designed to bear the weight of the low-voltage machine and you should not subject them to any **additional loading**. If appropriate, use suitable, adequately rated means of transportation, e.g. rope guides.

Before carrying out commissioning, remove the **transportation safety devices**. Use them again if the equipment is to be removed, or, if you do not need them any longer, return them to Baumüller GmbH in Nuremberg.

If the motors are to be kept in storage, ensure that the local conditions are **dry, dust-free and low-vibration** ($v_{\text{eff}} \leq 0.2 \text{ mm/s}$) to avoid damage due to bearings being idle. Before commissioning, measure the insulation resistance. With values of **1 MΩ** or less, dry the coil.

1.4 Long-term storage

If it is likely that the DC motors will be in storage for longer than 6 months or transported by sea and then subsequently stored for longer than 3 months, the system manufacturer must fit safety guards between the collector and the carbon brushes.

Grinding the collector

Once the units reach their installation site, the layer of oxide on the collector's bearing surface must be ground away with a corundum stone ("fine") or a carbon brush. Do not grind away more material than is absolutely necessary.

Draw off or blow away all traces of grinding dust.

Notice! - Do not use abrasive cloths.

These will smooth the disks and damage the collector even before it has been put into operation.

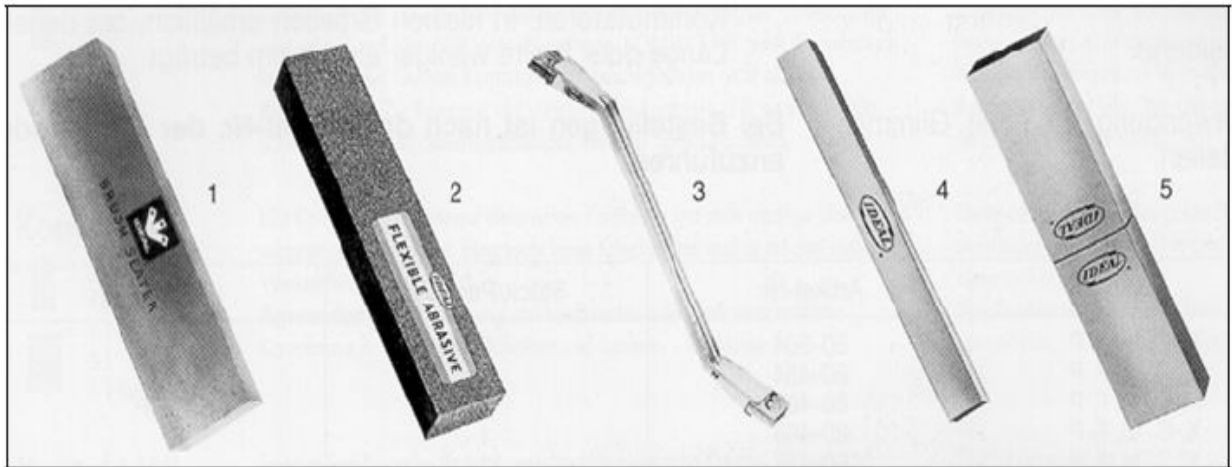

- 1 - Cleaning stone
- 2 - Flexible grinding, cleaning and polishing stone
- 3 - Collector cleaner
- 4 - Precision grinding stone for tooling insert
- 5 - Combined grinding stones in various grain sizes

It is not sufficient to clean the collector with alcohol or spirits.
 Notice! - Never use benzine, acetone, nitro or similar substances.

Safety information! Only trained personnel are permitted to grind collectors. Observation of specific safety regulations and precautionary measures to ensure electrical and mechanical safety are mandatory.

1.5 Setup

Ensure that the foundation is level, the pedestal or flange is fastened properly and that alignment is precise with direct coupling.

Avoid structurally dictated resonances at six times (with single-phase feeding double) the line frequency (the manufacturer accepts no responsibility whatsoever for damage that may result if you ignore this point!).

Remove any safety guards which might have been placed between the collector and the carbon brushes.

Turn the impeller **by hand** and check for any unusual grating sounds.

Check the direction of rotation in uncoupled mode (observe Section 1.5).

Use **only** appropriate tools to mount/remove drive elements such as pulley disks, couplings (warm them first) and cover them with a **guard**. Avoid inadmissible pulley belt tensions (refer to Section 3.4 for standard motors).

With special motor bearing and shaft end designs, consult the manufacturer for the permissible data.

In the case of **damage caused by overloading**, the manufacturer accepts no responsibility even during the warranty period.

The shaft end face or the rating plate shows the **active force status** of the motors (H = half feather key balancing, F = full feather key balancing).

When assembling the drive elements pay attention to the active force status!

In the case of versions with half feather keys (H), the coupling must also be balanced with a half feather key. Machine off any **protruding visible** portions of the feather key.

In the case of types with shaft ends pointing upwards, it is advisable to fit a protective cover; with types that have shaft ends pointing downwards, you must take precautions to prevent water entering the bearing. **Do not inhibit ventilation!**

In the case of types with shaft ends pointing upwards or downwards, **the customer** must fit a cover that stops contaminants from falling into the ventilation. Ventilation must not be inhibited and the exhaust air of neighbouring equipment must not be directly sucked in. In the motor's incoming and outgoing air areas, the distance to a neighbouring machine section must be at least the height of the motor shaft.

Commutation and the service life of the brush can be negatively affected by cooling air that is chemically contaminated or that contains dust. You can guarantee good carbon service life by ensuring that the moisture content of the air is not less than 1g/m^3 and not more than 15g/m^3

1.6 Electrical Connection

All work may only be carried out by **qualified** specialists, with the motor **idle, deenergized and secured from being switched on again**. This also applies to auxiliary circuits, e.g. an anti-condensation heater.

Check that the equipment is deenergized!

Exceeding the **tolerances specified in EN 60034/VDE 530 Part 1/IEC 34-1** i.e. voltage by $\pm 5\%$ or an awkward form factor due to the type of current converter feeding, increases the temperature rise and affects electromagnetic compatibility.

Observe the information on the rating plate and in the terminal diagram in the terminal box.

The equipment must be coupled up such that a **permanent, safe** electrical connection is maintained (no protruding wire ends), use the assigned cable tips.

Make a safe PE connection.

The smallest **clearances** between uninsulated, live parts and ground must be according to **VDE 0170/0171 Part 6 (EN 50019)**.

There may be **no** foreign bodies, dirt or damp in the terminal box. Seal any unneeded cable entry holes, and the terminal box itself **dust- and water-tight**.

Secure the **feather key** for test operation without drive elements. When connecting and installing **accessories** (e.g. tachometer generators, pulse encoders, brakes, temperature sensors, air-flow monitors, brush monitoring units) and **additional equipment**, always observe the **appropriate information**; if necessary, consult the motor manufacturer.

In the case of motors with brakes, **check** that **the brake** is working properly before carrying out commissioning.

1.7 Operation

Operating **without excitation** (similar to a **series-wound motor idling**), can lead to dangerous over-speed conditions and you must lock the machine to prevent this happening. Vibration levels of $v_{\text{eff}} \leq 3.5 \text{ mm/s}$ ($P_n \leq 15 \text{ KW}$) or 4.5 mm/s ($P_n > 15 \text{ KW}$) in coupled operation are insignificant.

If changes different from normal operation occur, e.g. **increased temperatures, noises or vibrations**, switch off the motor **if you are in doubt**. Find out the cause and contact the manufacturer if necessary. Never disable guards, even in test operation. When carrying out any **inspection and maintenance work**, observe Section 1.5 and the **details** in the **commissioning guide and maintenance instructions**.

After approximately 100 operating hours, carry out first-time inspection of the brushes (for wear), the commutator (for unusual discolouration), and the brush holders (for easy motion). After this, inspect these components again approximately every 600 operating hours depending on the degree of wear (refer to Section 4.1).

If the motor is fitted with ventilation with filter, you must carefully clean the filter every 100 operating hours, depending on the degree of contamination.

If a lot of dirt accumulates, clean the airways regularly. From time to time, open any **condensate drain holes** there may be on the equipment.

In the case of motors **without regreasing devices**, change the lubricant as advised by the manufacturer or after three years at the latest.

Regrease bearing assemblies that have regreasing devices **while the motor is running**.

If grease exit holes are sealed with plugs, **remove the plugs** before commissioning and seal the holes with grease.

Important: Observe the information on the rating plate for regreasing intervals!

Under unfavourable operating conditions, it may be necessary to considerably reduce the maintenance intervals!

Important !

You should always keep liquids and aggressive media, silicone and silicone compounds and their vapours away from the motors. The only exceptions to this rule are motors whose manufacturers have expressly designed them for specific applications (e.g. use out of doors) and which have appropriate protection. The manufacturer accepts no responsibility for damage resulting from ignoring this.



1.8 Electromagnetic Compatibility

Operation of the DC motor for its intended purpose must be in accordance with the requirements of **EMC Guideline 2004/108/EG**. The plant installer is responsible for correct installation, e.g. physical separation of the signal lines and the power cables, screened lines and cables, etc.

In the case of systems with converters, observe the manufacturer's EMC information.

1.9 Warranty

The warranty is dependent on this safety and commissioning information, as well as the data on any additional equipment, being observed. For more details, refer to the detailed **commissioning guide and maintenance instructions** below.

2 Information about the Product

2.1 Motor Type, Product Number and Technical Data

Refer to the rating plate on the motor for this information.

2.2 Types of Ventilation

Type GNA

With mounted radial fan, direction of cooling air from B to A

Standard ventilation version

A side

B side

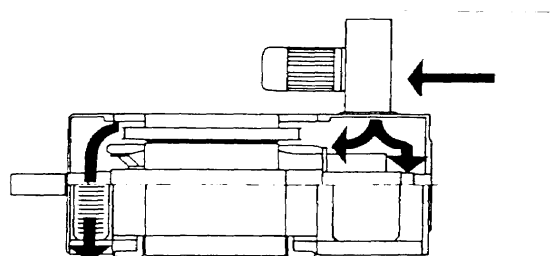

2.3 Cooling

Type GNA machines have a radial fan that is either mounted on top or on the side. The cooling air is taken in here at the fan's suction head and blown diametrically into the motor space, it is then diverted towards the shaft and blown out through the lateral openings on the end shield opposite.

Type AGN machines have a radial fan that is axially mounted on the B side. The cooling air is taken in at the fan's suction head and pressed through the machine towards the shaft and blown out through the lateral openings in the A end shield.

If a separate cooling unit is connected, the intake and exhaust openings have a connection option for pipe connection pieces. This type is identified as fGN in this case. The machine corresponds to protection type IP 23 in the case of a pipe connection on one side and a free exhaust opening; in the case of a pipe connection on both sides and a free exhaust opening, the machine has protection type IPR 44. The connection option for pipe connection pieces is also available for motors with mounted separately driven fans.

With force-ventilated motors, the cooling air volume remains constant regardless of the DC motor's speed. For this reason, you may continuously run these motors at the rated torque right down to the lowest speed values.

The machine achieves the maximum type rating (GNA rating) when the necessary cooling air volume has been raised and taken in on the B side.

If the cooling air is contaminated, it is vital to mount a fine dust filter. At the same time, you should install a heat monitoring relay to protect the motor from heating up above allowed limits.



	Technical Instructions Commissioning and Maintenance Guide	TAM 00 520 Page 8 / 18
---	---	----------------------------------

2.4 Necessary Cooling Air Volume and Pressure for fGN Motors

Size	Air Volume m ³ /s	Pressure Head Pa
100	0.08	420
112	0.10	380
132	0.22	800
160	0.32	1200
180	0.40	1200
200	0.50	1400
225	0.65	1350
250	0.85	2200
280	0.95	2300

These values apply to the direction of air flow from the B side to the A side. In the opposite direction, approximately 10% higher air volumes are needed.

2.5 Fan Assignment for Series Motors

Motor Type	Force Ventilation	Rated Current
Size		400V/50Hz
		A
GNA 100	BFB 398	0.33
AGN 100	BFB 398	0.33
GNA 112	BFB 398	0.33
AGN 112	BFB 398	0.33
GNA 132	BFB 635	1.4
AGN 132	BFB 635	1.4
GNA 160	BFB 752	3.8
AGN 160	BFB 752	3.8
GNA 180	BFB 752	3.8
AGN 180	BFB 752	3.8
GNA 200	BFB 880	8.1
AGN 200	BFB 880	8.1
GNA 225	BFB 880	8.1
AGN 225	BFB 880	8.1
GNA 250	FB D09	11.2
AGN 250	FB D09	11.2
GNA 280	FB D09	11.2
AGN 280	FB D09	11.2

Up to fan type BFB 880, separately driven fan motors are rated as standard for Δ/Y 200–265/345–460 V, 50/60 Hz.

In the case of FB D09 separately driven fans, Y 345 - 460 V, 50 Hz is intended as the supply voltage. For this reason, you must always observe the information on the fan motor's rating plate.

2.6 Noise Intensity for Series Motors

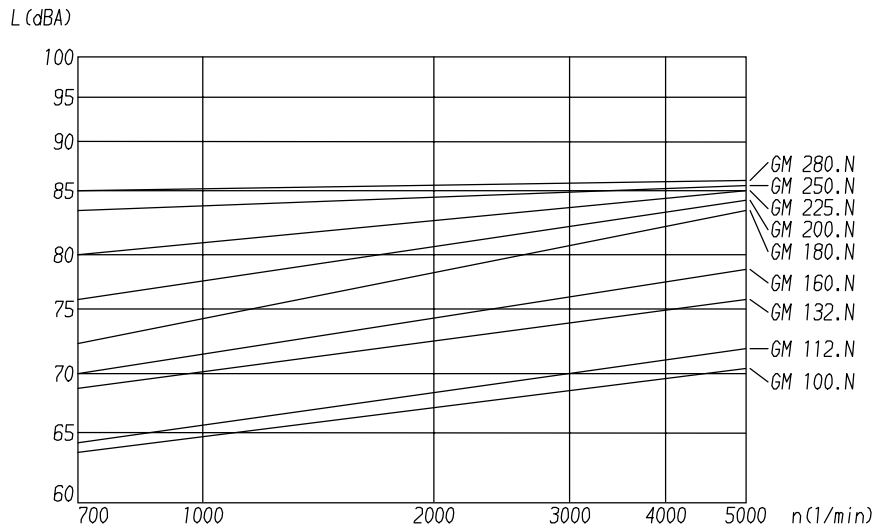

3 Operation

3.1 Instructions for Initial Commissioning

Compare the available mains voltages to the values specified on the rating plate. The impeller wheel on the mounted external fan must rotate in the direction of the arrow. Mount all the guards before starting commissioning

Important! Force-ventilated motors must only be run with separately driven fans.

In operation, the power unit and the motor coils are live! Never touch these components during operation! Connect measuring instruments only when the motor is deenergized and disconnected from the mains! After switching-off, the condensers are charged for several minutes and take at least five minutes to discharge.

Speed monitoring sub-systems in the motor must not only be complemented by a stand-alone monitoring sub-system by the motor in the case of speed-critical systems. This speed governor, which is independent of the feedback control, can be implemented by inductive, optical or centrifugal force dependent encoders.

Be particularly careful when touching the drive shaft directly or indirectly. You must only do this when the drive is stationary and disconnected from the mains! Safety equipment may never be dismantled or disabled



3.2 Wiring Diagrams

You connect the motor according to the supplied wiring diagrams. There are separate wiring diagrams for the main motor, the fan motor, the brake and the tachometer.

3.3 Notes

The motor must be mounted on the appropriate attachment points (pedestal or flange) in the installation position for which it was designed. When mounting, ensure that the motor is attached unwarped



Before mounting a pulley or coupling, lightly grease the shaft end. For mounting or removal, use the tapped hole in the shaft end.

You must not jar the shaft by hitting it on the end, since this may damage the shaft bearings and the position encoder.

If a belt drive is used, the radial forces that were used as the basis of configuration must not be exceeded.

The allowed radial forces F_R , which are specified in Section 3.4, apply to horizontal motor installation with no additional axial forces. If axial forces occur, consult the manufacturer.

3.4 Allowed Radial Forces (with Standard Motor)

Version with ball bearing on A-side



1 shaft end

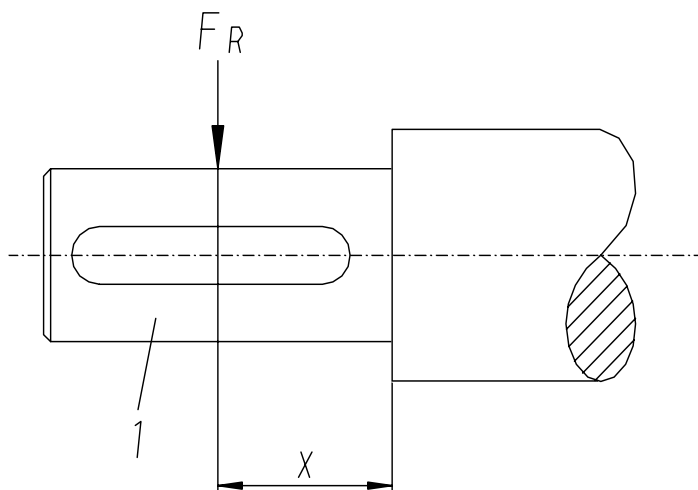

Details relating to the permissible radial force, F_R , can be found in the latest product list or planning instructions!

3.5 Operating Disturbances

Error	Possible Cause	Removing the Source of the Error
Motor doesn't start	Supply lead interrupted	Check connections
	Setting of brush yoke wrong	Adjust neutral zone
	Current limiting doesn't respond	Loading too high or increase current limiting
	Brake doesn't release	Check brake connection
Motor speed drops when under load	Overloading	Carry out performance measurement
	Voltage drops	Adjust neutral zone
	Setting of brush yoke wrong	Adjust neutral zone
Motor gets too hot	Overloading	Carry out performance measurement
	Insufficient cooling	Ensure that the cooling air can enter without hindrance
	Separately driven fan not running	Check connection of separately driven fan
	Current ripple too great	Check form factor, if necessary connect armature choke on input side
	Ambient temperature too high	Reduce performance
Severe brush sparking	Overloading	Carry out performance measurement
	Setting of brush yoke wrong	Adjust neutral zone
	Commutator surface very dirty	Clean commutator
	Commutator out-of-round or with flat points	Have commutator diameter-turned by specialists
	Lamellar insulation protruding	Have specialists scrape out insulation grooves and remove sharp edges
	Brushes worn out	Insert new brushes
	Current ripple too great	Check form factor, if necessary connect armature choke on input side
	Switching error in a section of coil	Have experts carry out checking
	Carbon brush sticks in holder	Ensure easy running
	Vibrations on the drive	Remove possible unbalance
	Unsuitable brush quality	Consult the manufacturer, stating the technical data and environmental factors
	Damage to coil	Get damage removed by specialists
	Brush life too short	Current ripple too great
		Connect armature choke on input side
Overloading		Carry out performance measurement
Current loading of carbon brush too low		Use genuine carbon brushes
Commutator surface affected		Find out the cause (dust, oil fumes, chemically active gases, etc.) and remove it
Brushes are of different or unsuitable qualities		Fit the machines with suitable brushes of consistent quality. Use genuine carbon brushes
Motor produces too much noise	Current ripple too great	Check form factor. Connect armature choke on input side
	Bearings warped, dirty or damaged	Realign the motor. Clean and grease the bearings or replace them
	Rotating parts unbalanced	Remove stimulation of vibration and possible armature unbalance
	Current converter vibrates	Optimize current converter
Speed is unstable	Current converter not set ideally	Optimize current converter
	Large differences in loading	Increase current limiting or use a more efficient device or motor
	Tachometer signal not constant	Check tachometer
Motor accelerates uncontrollably	Error in speed feedback, e.g. tachometer connected wrongly	Connect correct polarity
	Tachometer carbon brushes worn-out	Replace carbon brushes
	Tachometer lead interrupted	Lay a new tachometer lead

 BAUMÜLLER	Technical Instructions Commissioning and Maintenance Guide	TAM 00 520 Page 13 / 18
---	---	-----------------------------------

4 Corrective Maintenance

Important!



Before starting maintenance work, disconnect the machine from the mains. Retighten as specified all connections, e.g. screws, that were loosened during maintenance work.

If guards or safety devices are removed during repair or maintenance work, disable the machine. Replace the safety equipment immediately after completion of repair or maintenance work.

Each time you carry out maintenance, clean the entire internal space of the motor and blow out all the dust. After this, check the insulation resistance of the electrical conductors to earth. According to of EN 60204-1, page 55, this must not be less than **1 MΩ**

(See installation resistance test)

After any and all operator activity involving the machine, whether it be on the motor, the tachometer, the fan, the brake or the power converter, the owner must carry out acceptance testing and document it chronologically in the machine log (maintenance book, etc.) by entering the **name of the person/the firm carrying out acceptance testing, the date of testing, signature and report number etc.**

If this is not carried out, the owner may be faced with consequences relating to liability legislation.

For safety reasons, unauthorized additions or modifications to the drive are not allowed.

4.1 Brush-Holders, Carbon Brushes and Commutator of the Main Motor

Brush-holders and carbon brushes



Check all the brush holders and carbon brushes every 600 operating hours, or depending on the amount of wear, for wear, brush pressure, commutator brush mobility in the holder and firmness of contact between the brush and the brush shunt. You must change the carbon brush before the brush shunt damages the collector. The carbon brushes have wear marks. The carbon brush must not wear down below the mark.

Use only genuine replacement carbon brushes!

Reorders for replacement carbon brushes can only be accepted if you quote the motor's fabrication number.

Replacement carbon brushes are usually adapted to the radius of the commutator on the contact surface. If this is not the case, you must sand the brushes to size using fine sandpaper.

To do this, you place the sandpaper between the brushes and the commutator and turn the sandpaper evenly in the impeller's direction of rotation. (**Important:** the rough side of the sandpaper must be towards the carbon brushes—see figure below).

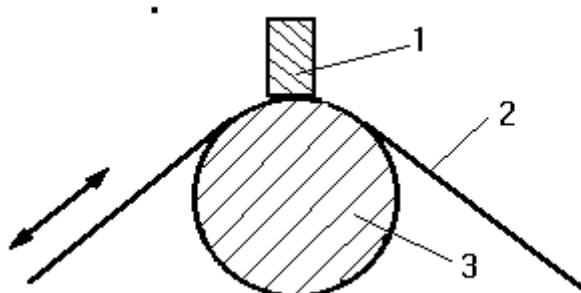

1 Carbon Brush 2 Sandpaper 3 Commutator

After sanding, carefully remove as much of the grit and fine particles as possible from the brush rocker and the commutator.

Twisting the brushgear

To change the carbon brushes, you release the locking screws from the operator opening on the terminal box side and loosen and twist the brushgear.

After changing the brushes, turn the brushgear back to its original position with the marks on the end shield and the brushgear lined up exactly with one another.

Commutator

Keep the commutator free of dust and oil: at least every 600 operating hours – or depending on the amount of wear, wipe off the oil with a dry rag and blow off any loose dust! Remove any damage, such as burn stains, beads of molten metal, rough areas and slight grooving, using progressively finer grades of sandpaper. While doing this, ensure that you don't sand the commutator out-of-round. Carefully blow out the grit!

The patina (the discolouration ranging from light to dark brown of the brush paths) shows that the equipment is operating properly and should never be removed. Out-of-round running surfaces, protruding segments, pitting and grooving can only be corrected by specialist machining (skimming).

Brush-holder position

Adjust the holder to a distance of about 1.5 mm to the commutator surface when the commutator has been outside diameter-turned.

	Technical Instructions Commissioning and Maintenance Guide	TAM 00 520 Page 15 / 18
---	---	-----------------------------------

4.2 Bearings

Depending on the operating conditions, (e.g. mode, temperature, speed and load), the service life of the bearings and sealing elements can differ greatly.

In the case of troublefree operation, we generally recommend the following maintenance procedures:

- replacement of the bearings after 20,000 running hours (The bearings are designed for a calculated service life of 20,000 running hours)
- replacement of the shaft sealing ring, if provided, and if no leaking is detected in the course of previous inspections, after approx. 5,000 running hours.

Motors up to size 200 are permanently lubricated; sizes 225-250 to A-S have regreasing mechanisms with grease regulation: sizes 280 and above to A- and B-S have regreasing mechanisms with grease regulation.

Lubrication intervals (in operating hours)

Size	Speed					Amount of grease with regreasing
	1,000 RPM	1,500 RPM	2,000 RPM	2,500 RPM	3,000 RPM	
225, A-S	7500	4500	3000	2000	1500	50 g
250, A-S	6500	4000	2500	2000	1500	65 g
280, A-S, B-S	6500	3500	2000	1500	----	75 g

The lubrication intervals can be increased by 1.5 times for versions with ball bearings at the drive end.

The lubrication intervals are based on bearing manufacturer data for normal operating conditions. Use only lithium base-saponified special rolling-contact bearing grease (e.g. Calypsol H 443) for initial or regreasing. Before carrying out regreasing, check that the bearings of machines without regreasing mechanisms are functioning correctly and replace them if necessary.

Bearing assignment with standard motor

Size	A Side	B Side
110	6208 2ZR C3	6306 2ZR C3
112	6210 2ZR C3	6209 2ZR C3
132	6212 2ZR C3	6211 2ZR C3
160	6214 2ZR C3	6212 2ZR C3
180	6213 C3	6310 2RSR C3
200	6314 C3	6310 2RSR C3
225	6316 C3	6311 2RSR C3
250	6219 C3	6313 2ZR C3
280	6220 C3	6316 C3

4.3 Intake opening for cooling air

When carry out maintenance work on the commutator, the intake opening for cooling air must be checked for dirt and, if necessary, cleaned.

In the case of heavy dirt deposits, which could, for example lead to the intake grid being blocked, it may be necessary to significantly increase the cleaning frequency.

4.4 Filters

If the motor is fitted with ventilation with filter, you must carefully clean the filter every 100 operating hours, depending on the degree of contamination. In unfavourable ambient conditions, the faster contamination of the filters may dictate considerably shorter cleaning intervals.

Dry dirt can be cleaned out of filters by sucking, blowing or tapping it out.

Wash filters contaminated with damp dirt in lukewarm water, to which you may need to add commercial detergent, rinse and dry them.

Important!

Very dirty filters lead to an increase in the motor temperature: in a worst case situation, this may lead to overheating and shut down the motor.



Use only original motor manufacturer replacement filters.

5 List of Spare Parts and Sectional Drawing

Important!

In all spare parts orders, specify the motor type, the motor and item numbers exactly as shown in the sectional drawing at the end of this document.

1 Housing	101 Cover A-S
	103 Cover B-S
6 End shield A-S	
7 End shield B-S	116 Feather key for shaft end
10 Bearing cap A-S, inside	259 Tachometer
11 Bearing cap B-S, inside	262 Tachometer carbons
22 Terminal box	304 Fan, complete
	307 Seal for fan
31 Impeller, complete	310 Fan motor, complete
38 Main pole and commu- tating pole	311 Fan housing
	312 Impeller wheel
61 Shaft	
	313 Filter
66 Roller-action bearing AS	314 Filter mat
67 Roller-action bearing BS	
70 Commutator	
72 Brush yoke	
73 Carbon brushes	

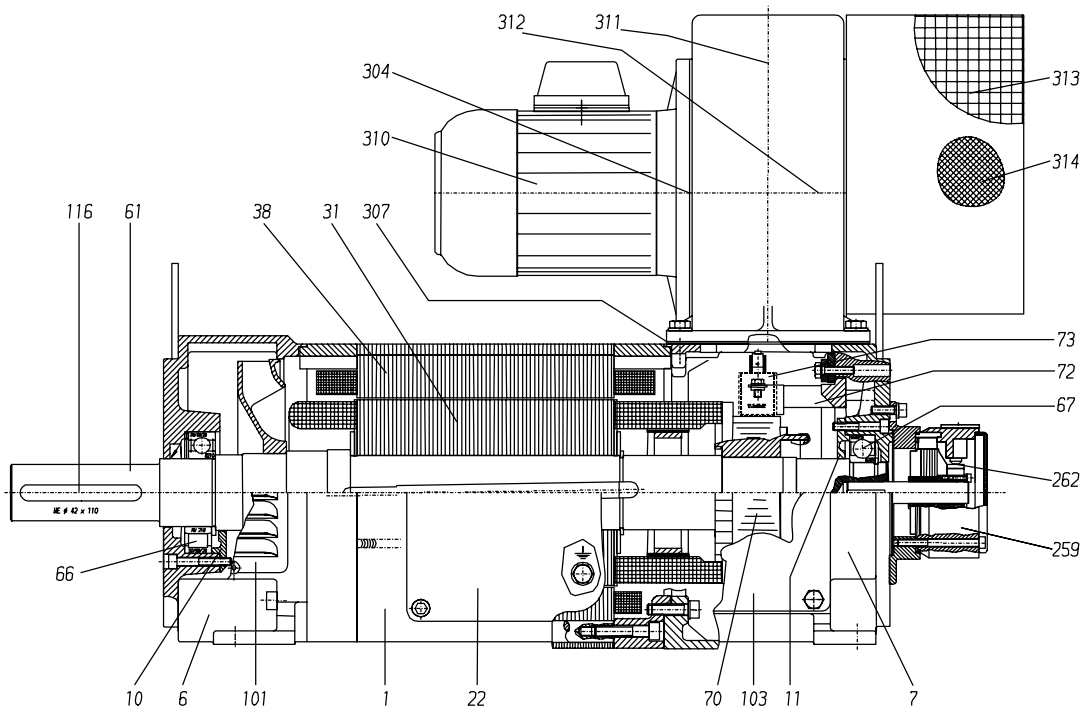
Sectional Drawing:

6 Decommissioning, Removal, and Disposal

At decommissioning of the motors, the following also applies:

- Disconnect the motor from the mains (refer to 1.6)
- If necessary carry out discharging (e.g. the condenser)



Take the steps below to dismantle the motor:

- disconnect the electrical connection
- release the motor attachment screws

The motor contains materials like steel, copper and insulation material.

You must disassemble the unit appropriately and dispose of the material separate.

Headquarters

Baumüller Nürnberg GmbH

Ostendstraße 80-90, DE-90482 Nürnberg
T: +49(0)911 5432-0, F: +49(0)911 5432-130
www.baumueller.com

Baumüller Anlagen-Systemtechnik GmbH & Co. KG

Ostendstraße 84, DE-90482 Nürnberg
T: +49(0)911 54408-0, F: +49(0)911 54408-769
www.baumueller.com

Baumüller Reparaturwerk GmbH & Co. KG

Andernacher Straße 19, DE-90411 Nürnberg
T: +49(0)9128 9255-0, F: +49(0)9128 9255-999
www.baumueller.com

Nürmont Installations GmbH & Co. KG

Am Keuper 14, DE-90475 Nürnberg
T: +49(0)9128 9255-0, F: +49(0)9128 9255-333
www.nuermont.com

Subsidiaries

Australia

Baumüller Australia Pty. Ltd.
19 Baker Street, Botany NSW 2019, Sydney, AU
T: +61 2 83350-100, F: +61 2 83350-169

Austria

Baumüller Austria Ges.mbH
Im Bäckerfeld 17, AT-4060 Leonding
T: +43(0)732 674414-0, F: +43(0)732 674414-32

Brazil

NC Service Indústria e Comércio Ltda.
Av. Tamboré, 1217 Barueri-SP, BR-06460-000
T: +55(0)11 4195-0502, F: +55(0)11 4195-2479

China

Baumüller Automation Equipment
Trading (Shanghai) Co. Ltd., Cailun Rd. 88,
Pudong Zhangjiang, 201203 Shanghai, CN
T: +86(0)21 5855 1533, F: +86(0)21 5855 9487

China

Beijing Yanghai Automation Technology Co., Ltd.
Room 1008, No.7, Huaqing Business Building,
Iluaqing Garden, Wudaokou, Haidian District,
100083 Beijing, CN
T: +86(0)10 8286 7980, F: +86(0)10 8286 7987

China

Sunary Automatic Technology Limited Company
3rd Floor No.476, Chunxiao Rd., Zhangjiang High-
Tech Park Pudong, Shanghai 201203, CN
T: +86(0)21 5080 9898, F: +86(0)21 5308 7675

Czech Republic, Slovakia

VAE Prosys s.r.o.
Varsavska 9a, CZ-70900 Ostrava
T: +420 596 616 555, F: +420 596 616 777

Denmark

Robotek EL & Teknik A/S
Blokken 31, Postbox 30, DK-3460 Birkerød
T: +45 4484 7360, F: +45 4484 4177

Finland

Kontram Oy
Olarinluoma 12, P.O.Box 88, FI-02201 Espoo
T: +358 9 8866 4500, F: +358 9 8866 4799

France

Baumüller France S.à.r.l.
Zone de la Malnoue 39, Avenue de l'Europe,
FR-77184 Emerainville
T: +33(0)1 6461 6622, F: +33(0)1 6461 6006

France

Baumüller France S.à.r.l. (Strasbourg)
9 rue de la Durance, FR-67100 Strasbourg
T: +33(0)3 8840 1251, F: +33(0)3 8840 0724

Germany - Darmstadt

Baumüller Nürnberg GmbH
Waldstraße 1, DE-64347 Griesheim
T: +49(0)6155 8430-00, F: +49(0)6155 8430-20

Germany - Düsseldorf

Baumüller Nürnberg GmbH
Jacob-Kaiser-Str. 7, DE-47877 Willich-Münchheim
T: +49(0)2154 487-0, F: +49(0)2154 487-59

Germany - Dresden

Baumüller Nürnberg GmbH
Nordstraße 57, DE-01917 Kamenz
T: +49(0)3578 3406-0, F: +49(0)3578 3406-50

Germany - Freiberg

Nürmont Installations GmbH & Co. KG
Am Junger Löwe Schacht 11, DE-09599 Freiberg
T: +49(0)3731 3084-0, F: +49(0)3731 3084-33

Germany - Hannover

Baumüller Nürnberg GmbH
Bohlenweg 10, DE-30853 Langenhagen
T: +49(0)511 771 968-0, F: +49(0)511 771 968-77

Germany - München

Baumüller Reparaturwerk GmbH & Co. KG
Meglingerstraße 58, DE-81477 München
T: +49(0)89 748 898-0, F: +49(0)89 748 898-55

Germany - Nürnberg

Baumüller Nürnberg GmbH
Ostendstraße 80-90, DE-90482 Nürnberg
T: +49(0)911 5432-501, F: +49(0)911 5432-510

Germany - Stuttgart

Baumüller Nürnberg GmbH
Im Ghai 12, DE-73776 Altbach
T: +49(0)7153 61036-0, F: +49(0)7153 61036-29

Germany - Stuttgart

Nürmont Installations GmbH & Co. KG
Im Ghai 12, DE-73776 Altbach
T: +49(0)7153 92798-0, F: +49(0)7153 92798-99

Great Britain

Baumüller (UK) Ltd.
14 Redlands Centre, GB-Coulsdon,
Surrey CR5 2HT
T: +44(0)208 763-2990, F: +44(0)208 763-2959

India

Baumüller KAT India Pvt. Ltd.
4th Floor, Commerce Avenue, Mahaganesh
Colony, Paud Road, IN-411038 Pune
T: +91 20 254596 82, F: +91 20 254596 84

Italy

Baumüller Italia S.r.l.,
Viale Italia 12, IT-20094 Corsico (Mi)
T: +39 02 45100-181, F: +39 02 45100-426

Netherlands

Baumüller Benelux B.V.
Platinastraat 141, NL-2718 SR Zoetermeer
T: +31(0)79 3614-290, F: +31(0)79 3614-339

Poland

Mekelburger Polska
Ul. Kóscielna 39 F/3, PL-60537 Poznań,
T: +48(0)61 8481 520, F: +48(0)61 8481 520

Russia, Kazakhstan

Prosensor
Zavadoskaj 1b/2, Moscow, 124365, RU,
T: +7 495 6428 476, F: +7 495 6428 477

Slovenia

Baumüller Dravinja d.o.o.
Delavska cesta 10, SI-3210 Slovenske-Konjice
T: +386 3 75723-00, F: +386 3 75723-32/33

South Korea

Bomac Systems
712 Yucheon Factophia, 196 Anyang-7 dong,
Mananku, Anyangsi, Kyungkido 430-017, KR
T: +82 31 467-2030, F: +82 31 467-2033

South Africa

Motion Tronic cc
Unit 18 Wareing Park, ZA-3610 Pinetown
T: +27 31 7011620, F: +27 86 6150597

Spain

Baumüller Ibérica S.A.
C/Ausias Marc 13 1° 2ª, ES-08010 Barcelona
T: +34(0)93 342 69 26, F: +34(0)93 270 13 21

Switzerland

Baumüller Suisse S.A.
Rue Gallié 9, CH-1400 Yverdon-les Bains
T: +41(0)24 420 77-70, F: +41(0)24 420 77-79

Switzerland

Baumüller Schweiz AG (Büro Ost)
Oberwiesenstraße 75, CH-8500 Frauenfeld
T: +41(0)52 723 28-00, F: +41(0)52 723 28-01

Thailand

Mr. Tom Sale and Service Co., Ltd.
39/9 Moo 1, Tepkanjana Rd., Tambol Nadee
Amphur Muang, TH-74000 Samutsakorn
T: +66 34 854932-4, F: +66 34 854935

Turkey

Baumüller Motor Kontrol Sistem
San. Ve Tic. Ltd. Sti
Girne Mah., Kücükalyalı Is Merkezi, B Blok No. 12,
Maltepe, TR-34852 Maltepe - Istanbul
T: +90(0)216 519-9071, F: +90(0)216 519-9072

USA

Baumüller Inc.
117 West Dudley Town Road,
US-Bloomfield, CT 06002
T: +1 860-243-0232, F: +1 860-286-3080

USA

Baumüller Inc.
117 West Elmhurst Road, Mount Prospect,
IL 60005,
T: +1 847-956-7392, F: +1 847-956-7925

USA

Baumüller-Nuermont Corp.
1858 S. Elmhurst Road, Mount Prospect,
IL 60005,
T: +1 847-956-7392, F: +1 847-956-7925

USA

Baumüller-Nuermont Corp.
2650 Pleasantdale Road, Suite 15,
US-Doraville, GA 30340
T: +1 678-291-0535, F: +1 678-291-0537

Venezuela, Colombia, Ecuador

Nimbus International C.A.
C.C. Parque Tuy, Local P-18,
VE-Ocumare del Tuy, 1209
T: +58 239 225 1347, F: +58 239 225 7149